

BHTS ZZ 350°

Beco Plus

Extreme Temperature

Maintenance Free + High Speed Bearings



6000 SERIE

Designation	Bore (B)	Diam (D)	Width (W)	Speed, RPM	Static Load, kN at 350°C	Static Load, kN at 20°C
6000 BHTS ZZ 350° Beco Plus	10	26	8	564	1,35	1,96
6001 BHTS ZZ 350° Beco Plus	12	28	8	524	1,63	2,36
6002 BHTS ZZ 350° Beco Plus	15	32	9	484	1,97	2,85
6003 BHTS ZZ 350° Beco Plus	17	35	10	444	2,24	3,25
6004 BHTS ZZ 350° Beco Plus	20	42	12	400	3,45	5,00
6005 BHTS ZZ 350° Beco Plus	25	47	12	340	4,04	5,85
6006 BHTS ZZ 350° Beco Plus	30	55	13	260	5,52	8,00
6007 BHTS ZZ 350° Beco Plus	35	62	14	220	7,17	10,4
6008 BHTS ZZ 350° Beco Plus	40	68	15	200	8,14	11,8
6009 BHTS ZZ 350° Beco Plus	45	75	16	180	9,86	14,3
6010 BHTS ZZ 350° Beco Plus	50	80	16	170	10,76	15,6
6011 BHTS ZZ 350° Beco Plus	55	90	18	150	14,62	21,2
6012 BHTS ZZ 350° Beco Plus	60	95	18	140	16,00	23,2
6013 BHTS ZZ 350° Beco Plus	65	100	18	126	17,24	25,0
6014 BHTS ZZ 350° Beco Plus	70	110	20	120	21,72	31,5
6015 BHTS ZZ 350° Beco Plus	75	115	20	100	23,45	34,0

6200 SERIE

Designation	Bore (B)	Diam (D)	Width (W)	Speed, RPM	Static Load, kN at 350°C	Static Load, kN at 20°C
6200 BHTS ZZ 350° Beco Plus	10	30	9	524	1,79	2,60
6201 BHTS ZZ 350° Beco Plus	12	32	10	484	2,14	3,10
6202 BHTS ZZ 350° Beco Plus	15	35	11	360	2,59	3,75
6203 BHTS ZZ 350° Beco Plus	17	40	12	350	3,28	4,75
6204 BHTS ZZ 350° Beco Plus	20	47	14	300	4,52	6,55
6205 BHTS ZZ 350° Beco Plus	25	52	15	280	5,52	8,00
6206 BHTS ZZ 350° Beco Plus	30	62	16	220	7,72	11,2
6207 BHTS ZZ 350° Beco Plus	35	72	17	200	10,55	15,3
6208 BHTS ZZ 350° Beco Plus	40	80	18	170	12,41	18,0
6209 BHTS ZZ 350° Beco Plus	45	85	19	160	14,06	20,4
6210 BHTS ZZ 350° Beco Plus	50	90	20	150	16,55	24,0
6211 BHTS ZZ 350° Beco Plus	55	100	21	134	20,00	29,0
6212 BHTS ZZ 350° Beco Plus	60	110	22	120	24,83	36,0
6213 BHTS ZZ 350° Beco Plus	65	120	23	106	28,62	41,5
6214 BHTS ZZ 350° Beco Plus	70	125	24	100	30,35	44,0
6215 BHTS ZZ 350° Beco Plus	75	130	25	100	33,79	49,0

6300 SERIE

Designation	Bore (B)	Diam (D)	Width (W)	Speed, RPM	Static Load, kN at 350°C	Static Load, kN at 20°C
6300 BHTS ZZ 350° Beco Plus	10	35	11	440	2,38	3,45
6301 BHTS ZZ 350° Beco Plus	12	37	12	400	2,86	4,15
6302 BHTS ZZ 350° Beco Plus	15	42	13	360	3,72	5,40
6303 BHTS ZZ 350° Beco Plus	17	47	14	320	4,52	6,55
6304 BHTS ZZ 350° Beco Plus	20	52	15	280	5,86	8,50
6305 BHTS ZZ 350° Beco Plus	25	62	17	220	7,86	11,4
6306 BHTS ZZ 350° Beco Plus	30	72	19	190	11,24	16,3
6307 BHTS ZZ 350° Beco Plus	35	80	21	170	13,10	19,0
6308 BHTS ZZ 350° Beco Plus	40	90	23	150	17,24	25,0
6309 BHTS ZZ 350° Beco Plus	45	100	25	134	22,06	32,0
6310 BHTS ZZ 350° Beco Plus	50	110	27	120	26,21	38,0
6311 BHTS ZZ 350° Beco Plus	55	120	29	106	32,76	47,5
6312 BHTS ZZ 350° Beco Plus	60	130	31	100	35,86	52,0
6313 BHTS ZZ 350° Beco Plus	65	140	33	100	41,38	60,0
6314 BHTS ZZ 350° Beco Plus	70	150	35	100	46,90	68,0
6315 BHTS ZZ 350° Beco Plus	75	160	37	100	52,76	76,5

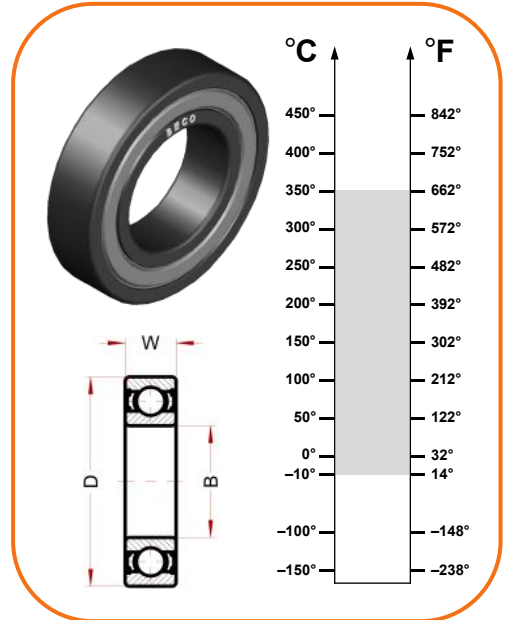

Technical characteristics:

- Bearing material: steel AISI 52100 (Chrome) stabilized to the application
- Treatment of manganese phosphate coating on all steel parts of the bearing
- Radial Clearance 4x C5
- Shields type ZZ
- Lubricated for entire life with BECO grease-compound for temperatures up to 375°C
- Do not need additional lubrication

Fields of application:

- Paint Ovens
- Steel industry
- Furnaces for Ceramic Industry
- Trolley Industry, Trolleys for Brick Kilns Industry

Advantages:

- The Most Performant Bearing on the market
- Up to 3 times more speed than any other competitors at the max. temperature



12100 Cuneo - Italy

phone: 0039 0171 66883

mail: office@becoitalia.biz

www.becoitalia.biz