

BHTS ZZ 280°

Extreme Temperature Bearings



6000 SERIE

Designation	Bore (B)	Diam (D)	Width (W)	Speed, RPM	Static Load, kN at 280°C	Static Load, kN at 20°C
6000 BHTS ZZ 280°	10	26	8	2240	1,40	1,96
6001 BHTS ZZ 280°	12	28	8	2080	1,69	2,36
6002 BHTS ZZ 280°	15	32	9	1920	2,04	2,85
6003 BHTS ZZ 280°	17	35	10	1760	2,33	3,25
6004 BHTS ZZ 280°	20	42	12	1600	3,58	5,00
6005 BHTS ZZ 280°	25	47	12	1360	4,18	5,85
6006 BHTS ZZ 280°	30	55	13	1040	5,72	8,00
6007 BHTS ZZ 280°	35	62	14	880	7,43	10,4
6008 BHTS ZZ 280°	40	68	15	800	8,43	11,8
6009 BHTS ZZ 280°	45	75	16	720	10,22	14,3
6010 BHTS ZZ 280°	50	80	16	680	11,14	15,6
6011 BHTS ZZ 280°	55	90	18	600	15,14	21,2
6012 BHTS ZZ 280°	60	95	18	560	16,57	23,2
6013 BHTS ZZ 280°	65	100	18	504	17,86	25,0
6014 BHTS ZZ 280°	70	110	20	480	22,50	31,5
6015 BHTS ZZ 280°	75	115	20	448	24,29	34,0
6016 BHTS ZZ 280°	80	125	22	400	28,57	40,0
6017 BHTS ZZ 280°	85	130	22	380	30,64	42,9
6018 BHTS ZZ 280°	90	140	24	360	35,64	49,9
6019 BHTS ZZ 280°	95	145	24	340	38,53	53,9
6020 BHTS ZZ 280°	100	150	24	300	38,53	53,9

6200 SERIE

Designation	Bore (B)	Diam (D)	Width (W)	Speed, RPM	Static Load, kN at 280°C	Static Load, kN at 20°C
6200 BHTS ZZ 280°	10	30	9	2080	1,86	2,60
6201 BHTS ZZ 280°	12	32	10	1920	2,22	3,10
6202 BHTS ZZ 280°	15	35	11	1600	2,68	3,75
6203 BHTS ZZ 280°	17	40	12	1440	3,39	4,75
6204 BHTS ZZ 280°	20	47	14	1200	4,68	6,55
6205 BHTS ZZ 280°	25	52	15	1120	5,71	8,00
6206 BHTS ZZ 280°	30	62	16	880	8,00	11,2
6207 BHTS ZZ 280°	35	72	17	760	10,93	15,3
6208 BHTS ZZ 280°	40	80	18	680	12,86	18,0
6209 BHTS ZZ 280°	45	85	19	640	14,57	20,4
6210 BHTS ZZ 280°	50	90	20	600	17,14	24,0
6211 BHTS ZZ 280°	55	100	21	536	20,71	29,0
6212 BHTS ZZ 280°	60	110	22	480	25,71	36,0
6213 BHTS ZZ 280°	65	120	23	424	29,64	41,5
6214 BHTS ZZ 280°	70	125	24	400	31,43	44,0
6215 BHTS ZZ 280°	75	130	25	384	35,00	49,0
6216 BHTS ZZ 280°	80	140	26	350	39,29	55,0
6217 BHTS ZZ 280°	85	150	28	330	45,72	64,0
6218 BHTS ZZ 280°	90	160	30	310	52,50	73,5
6219 BHTS ZZ 280°	95	170	32	300	58,21	81,5
6220 BHTS ZZ 280°	100	180	34	290	66,43	93,0

6300 SERIE

Designation	Bore (B)	Diam (D)	Width (W)	Speed, RPM	Static Load, kN at 280°C	Static Load, kN at 20°C
6300 BHTS ZZ 280°	10	35	11	1760	2,46	3,45
6301 BHTS ZZ 280°	12	37	12	1600	2,96	4,15
6302 BHTS ZZ 280°	15	42	13	1440	3,86	5,40
6303 BHTS ZZ 280°	17	47	14	1280	4,68	6,55
6304 BHTS ZZ 280°	20	52	15	1120	6,07	8,50
6305 BHTS ZZ 280°	25	62	17	880	8,14	11,4
6306 BHTS ZZ 280°	30	72	19	760	11,64	16,3
6307 BHTS ZZ 280°	35	80	21	680	13,57	19,0
6308 BHTS ZZ 280°	40	90	23	600	17,86	25,0
6309 BHTS ZZ 280°	45	100	25	536	22,86	32,0
6310 BHTS ZZ 280°	50	110	27	480	27,14	38,0
6311 BHTS ZZ 280°	55	120	29	424	33,93	47,5
6312 BHTS ZZ 280°	60	130	31	400	37,14	52,0
6313 BHTS ZZ 280°	65	140	33	360	42,86	60,0
6314 BHTS ZZ 280°	70	150	35	344	32,86	68,0
6315 BHTS ZZ 280°	75	160	37	320	54,64	76,5
6316 BHTS ZZ 280°	80	170	39	300	61,79	86,5
6317 BHTS ZZ 280°	85	180	41	290	68,93	96,5
6318 BHTS ZZ 280°	90	190	43	270	77,14	108,0
6319 BHTS ZZ 280°	95	200	45	250	84,29	118,0
6320 BHTS ZZ 280°	100	215	47	230	100,0	140,0

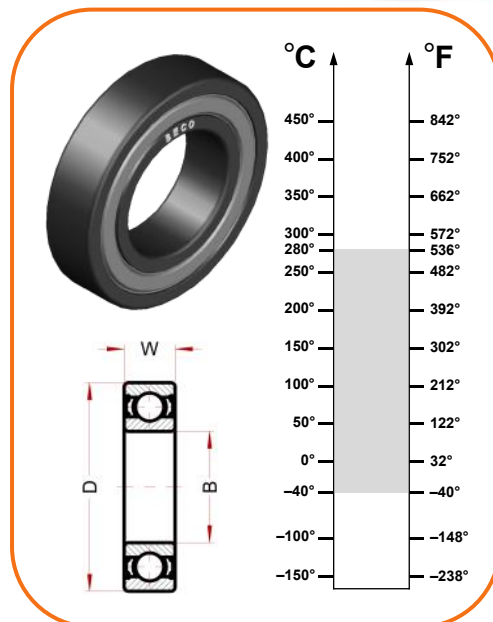

Technical characteristics:

- Bearing material: steel AISI 52100 (Chrome) stabilized to the application
- Treatment of manganese phosphate coating on all steel parts of the bearing
- Radial Clearance 4xC5
- Shields type ZZ
- Lubricated for entire life with PTFE based on silicone free grease for temperatures up to 280°C
- Grease food approved
- Do not need additional lubrication
- MICRO, 61800 & 61900 Series bearings also available

Fields of application:

- Paint Ovens
- Steel industry
- Furnaces for Ceramic Industry
- Trolley Industry, Trolleys for Brick Kilns Industry



12100 Cuneo - Italy

phone: 0039 0171 66883

mail: office@becoitalia.biz

www.becoitalia.biz