

# BHTS ZZ 280°

## Extreme Temperature Bearings



MICRO SERIE

Designation	Bore (B)	Diam (D)	Width (W)	Speed, RPM	Static Load, kN at 280°C	Static Load, kN at 20°C
613/3 BHTS ZZ 280°	3	8	3	2300	0,11	0,16
623 BHTS ZZ 280°	3	10	4	2300	0,13	0,18
604 BHTS ZZ 280°	4	12	4	2300	0,24	0,34
624 BHTS ZZ 280°	4	13	5	2300	0,24	0,34
605 BHTS ZZ 280°	5	14	5	2300	0,30	0,42
625 BHTS ZZ 280°	5	16	5	2300	0,30	0,42
606 BHTS ZZ 280°	6	17	6	2300	0,60	0,85
626 BHTS ZZ 280°	6	19	6	2300	0,60	0,85
607 BHTS ZZ 280°	7	19	6	2300	0,60	0,85
627 BHTS ZZ 280°	7	22	7	2200	0,79	1,10
608 BHTS ZZ 280°	8	22	7	2100	0,79	1,10
628 BHTS ZZ 280°	8	24	8	2000	0,79	1,10
609 BHTS ZZ 280°	9	24	7	1900	0,93	1,30
629 BHTS ZZ 280°	9	26	8	1800	1,12	1,57

61800 SERIE

Designation	Bore (B)	Diam (D)	Width (W)	Speed, RPM	Static Load, kN at 280°C	Static Load, kN at 20°C
61800 BHTS ZZ 280°	10	19	5	2240	0,38	0,53
61801 BHTS ZZ 280°	12	21	5	2080	0,68	0,95
61802 BHTS ZZ 280°	15	24	5	1920	0,89	1,25
61803 BHTS ZZ 280°	17	26	5	1760	1,04	1,45
61804 BHTS ZZ 280°	20	32	7	1600	1,60	2,24
61805 BHTS ZZ 280°	25	37	7	1360	2,00	2,80
61806 BHTS ZZ 280°	30	42	7	1040	2,39	3,35
61807 BHTS ZZ 280°	35	47	7	880	2,57	3,60
61808 BHTS ZZ 280°	40	52	7	800	3,04	4,25
61809 BHTS ZZ 280°	45	58	7	720	4,00	5,60
61810 BHTS ZZ 280°	50	65	7	680	4,50	6,30
61811 BHTS ZZ 280°	55	72	9	600	6,07	8,50
61812 BHTS ZZ 280°	60	78	10	560	7,86	11,0
61813 BHTS ZZ 280°	65	85	10	504	8,57	12,0
61814 BHTS ZZ 280°	70	90	10	480	8,93	12,5
61815 BHTS ZZ 280°	75	95	10	448	9,57	13,4

61900 SERIE

Designation	Bore (B)	Diam (D)	Width (W)	Speed, RPM	Static Load, kN at 280°C	Static Load, kN at 20°C
61900 BHTS ZZ 280°	10	22	6	2240	0,54	0,75
61901 BHTS ZZ 280°	12	24	6	2080	0,69	0,97
61902 BHTS ZZ 280°	15	28	7	1920	1,45	2,03
61903 BHTS ZZ 280°	17	30	7	1760	1,64	2,30
61904 BHTS ZZ 280°	20	37	9	1600	2,57	3,60
61905 BHTS ZZ 280°	25	42	9	1360	2,86	4,00
61906 BHTS ZZ 280°	30	47	9	1040	3,23	4,52
61907 BHTS ZZ 280°	35	55	10	880	4,43	6,20
61908 BHTS ZZ 280°	40	62	12	800	6,64	9,30
61909 BHTS ZZ 280°	45	68	12	720	7,00	9,80
61910 BHTS ZZ 280°	50	72	12	680	7,43	10,4
61911 BHTS ZZ 280°	55	80	13	600	8,14	11,4
61912 BHTS ZZ 280°	60	85	13	560	8,57	12,0
61913 BHTS ZZ 280°	65	90	13	504	9,57	13,4
61914 BHTS ZZ 280°	70	100	16	480	13,0	18,3
61915 BHTS ZZ 280°	75	105	16	448	13,7	19,3

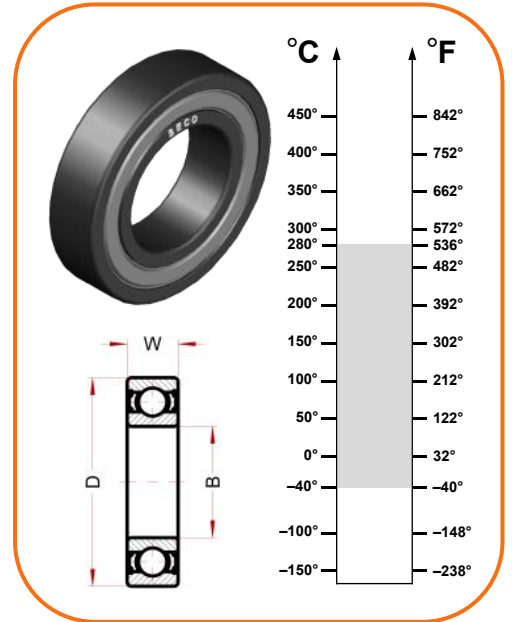

### Technical characteristics:

- Bearing material: steel AISI 52100 (Chrome) stabilized to the application
- Treatment of manganese phosphate coating on all steel parts of the bearing
- Radial Clearance 4x C5
- Shields type ZZ
- Lubricated for entire life with PTFE based on silicone free grease for temperatures up to 280°C
- Grease food approved
- Do not need additional lubrication

### Fields of application:

- Paint Ovens
- Steel industry
- Furnaces for Ceramic Industry
- Trolley Industry, Trolleys for Brick Kilns Industry



12100 Cuneo - Italy

phone: 0039 0171 66883

mail: office@becoitalia.biz

www.becoitalia.biz