

BHTS FB 450°

Beco Plus

Extreme Temperature Bearings



6000 SERIE

Designation	Bore (B)	Diam (D)	Width (W)	Speed, RPM	Static Load, kN at 450°C	Static Load, kN at 20°C
6000 BHTS FB 450° Beco Plus	10	26	8	90	1,22	2,35
6001 BHTS FB 450° Beco Plus	12	28	8	85	1,47	2,83
6002 BHTS FB 450° Beco Plus	15	32	9	80	1,78	3,42
6003 BHTS FB 450° Beco Plus	17	35	10	75	2,03	3,90
6004 BHTS FB 450° Beco Plus	20	42	12	70	3,12	6,00
6005 BHTS FB 450° Beco Plus	25	47	12	65	3,65	7,02
6006 BHTS FB 450° Beco Plus	30	55	13	60	5,00	9,60
6007 BHTS FB 450° Beco Plus	35	62	14	55	6,50	12,48
6008 BHTS FB 450° Beco Plus	40	68	15	50	7,37	14,16
6009 BHTS FB 450° Beco Plus	45	75	16	45	8,93	17,16
6010 BHTS FB 450° Beco Plus	50	80	16	40	9,75	18,72
6011 BHTS FB 450° Beco Plus	55	90	18	40	13,25	25,44
6012 BHTS FB 450° Beco Plus	60	95	18	40	14,50	27,84
6013 BHTS FB 450° Beco Plus	65	100	18	40	15,62	30,00
6014 BHTS FB 450° Beco Plus	70	110	20	40	19,69	37,80
6015 BHTS FB 450° Beco Plus	75	115	20	40	21,25	40,80

6200 SERIE

Designation	Bore (B)	Diam (D)	Width (W)	Speed, RPM	Static Load, kN at 450°C	Static Load, kN at 20°C
6200 BHTS FB 450° Beco Plus	10	30	9	90	1,62	3,12
6201 BHTS FB 450° Beco Plus	12	32	10	85	1,93	3,72
6202 BHTS FB 450° Beco Plus	15	35	11	80	2,34	4,50
6203 BHTS FB 450° Beco Plus	17	40	12	75	2,97	5,70
6204 BHTS FB 450° Beco Plus	20	47	14	70	4,09	7,86
6205 BHTS FB 450° Beco Plus	25	52	15	65	5,00	9,60
6206 BHTS FB 450° Beco Plus	30	62	16	60	7,00	13,4
6207 BHTS FB 450° Beco Plus	35	72	17	55	9,56	18,3
6208 BHTS FB 450° Beco Plus	40	80	18	50	11,2	21,6
6209 BHTS FB 450° Beco Plus	45	85	19	45	12,7	24,4
6210 BHTS FB 450° Beco Plus	50	90	20	40	15,0	28,8
6211 BHTS FB 450° Beco Plus	55	100	21	40	18,1	34,8
6212 BHTS FB 450° Beco Plus	60	110	22	40	22,5	43,2
6213 BHTS FB 450° Beco Plus	65	120	23	40	25,9	49,8
6214 BHTS FB 450° Beco Plus	70	125	24	40	27,5	52,8
6215 BHTS FB 450° Beco Plus	75	130	25	40	30,6	58,8

6300 SERIE

Designation	Bore (B)	Diam (D)	Width (W)	Speed, RPM	Static Load, kN at 450°C	Static Load, kN at 20°C
6300 BHTS FB 450° Beco Plus	10	35	11	90	2,15	4,14
6301 BHTS FB 450° Beco Plus	12	37	12	85	2,60	4,98
6302 BHTS FB 450° Beco Plus	15	42	13	80	3,38	6,48
6303 BHTS FB 450° Beco Plus	17	47	14	75	4,09	7,86
6304 BHTS FB 450° Beco Plus	20	52	15	70	5,30	10,2
6305 BHTS FB 450° Beco Plus	25	62	17	65	7,13	13,6
6306 BHTS FB 450° Beco Plus	30	72	19	60	10,1	19,5
6307 BHTS FB 450° Beco Plus	35	80	21	55	11,8	22,8
6308 BHTS FB 450° Beco Plus	40	90	23	50	15,6	30,0
6309 BHTS FB 450° Beco Plus	45	100	25	45	20,0	38,4
6310 BHTS FB 450° Beco Plus	50	110	27	40	23,7	45,6
6311 BHTS FB 450° Beco Plus	55	120	29	40	29,6	57,0
6312 BHTS FB 450° Beco Plus	60	130	31	40	32,5	62,4
6313 BHTS FB 450° Beco Plus	65	140	33	40	37,5	72,0
6314 BHTS FB 450° Beco Plus	70	150	35	40	42,5	81,6
6315 BHTS FB 450° Beco Plus	75	160	37	40	47,8	91,8

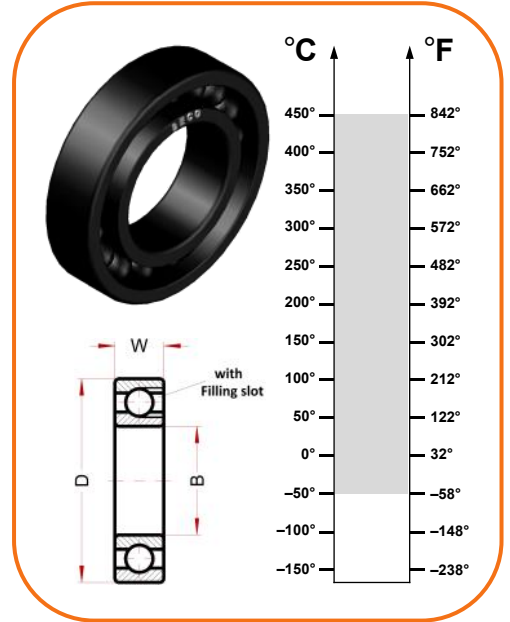

Technical characteristics:

- Bearing material: steel AISI 52100 (Chrome) stabilized to the application
- Treatment of manganese phosphate coating on all steel parts of the bearing + Treatment of ceramic coating
- Radial Clearance 4xC5
- Bearing running open
- Dry lubrication by coating

Fields of application:

- Pyrolysis Ovens
- Steel industry
- Furnaces for Ceramic Industry
- Trolley Industry, Trolleys for Brick Kilns Industry



12100 Cuneo - Italy

phone: 0039 0171 66883

mail: office@becoitalia.biz

www.becoitalia.biz