

# BHTS FB 400°

## Extreme Temperature Bearings



6000 SERIE

Designation	Bore (B)	Diam (D)	Width (W)	Speed, RPM	Static Load, kN at 400°C	Static Load, kN at 20°C
6000 BHTS FB 400°	10	26	8	90	1,35	2,35
6001 BHTS FB 400°	12	28	8	85	1,63	2,83
6002 BHTS FB 400°	15	32	9	80	1,97	3,42
6003 BHTS FB 400°	17	35	10	75	2,24	3,90
6004 BHTS FB 400°	20	42	12	70	3,45	6,00
6005 BHTS FB 400°	25	47	12	65	4,03	7,02
6006 BHTS FB 400°	30	55	13	60	5,52	9,60
6007 BHTS FB 400°	35	62	14	55	7,17	12,48
6008 BHTS FB 400°	40	68	15	50	8,14	14,16
6009 BHTS FB 400°	45	75	16	45	9,86	17,16
6010 BHTS FB 400°	50	80	16	40	10,76	18,72
6011 BHTS FB 400°	55	90	18	40	14,62	25,44
6012 BHTS FB 400°	60	95	18	40	16,00	27,84
6013 BHTS FB 400°	65	100	18	40	17,24	30,00
6014 BHTS FB 400°	70	110	20	40	21,72	37,80
6015 BHTS FB 400°	75	115	20	40	23,45	40,80

6200 SERIE

Designation	Bore (B)	Diam (D)	Width (W)	Speed, RPM	Static Load, kN at 400°C	Static Load, kN at 20°C
6200 BHTS FB 400°	10	30	9	90	1,79	3,12
6201 BHTS FB 400°	12	32	10	85	2,14	3,72
6202 BHTS FB 400°	15	35	11	80	2,59	4,50
6203 BHTS FB 400°	17	40	12	75	3,28	5,70
6204 BHTS FB 400°	20	47	14	70	4,52	7,86
6205 BHTS FB 400°	25	52	15	65	5,52	9,60
6206 BHTS FB 400°	30	62	16	60	7,72	13,44
6207 BHTS FB 400°	35	72	17	55	10,55	18,36
6208 BHTS FB 400°	40	80	18	50	12,41	21,60
6209 BHTS FB 400°	45	85	19	45	14,07	24,48
6210 BHTS FB 400°	50	90	20	40	16,55	28,80
6211 BHTS FB 400°	55	100	21	40	20,00	34,80
6212 BHTS FB 400°	60	110	22	40	24,83	43,20
6213 BHTS FB 400°	65	120	23	40	28,62	49,80
6214 BHTS FB 400°	70	125	24	40	30,34	52,80
6215 BHTS FB 400°	75	130	25	40	33,80	58,80

6300 SERIE

Designation	Bore (B)	Diam (D)	Width (W)	Speed, RPM	Static Load, kN at 400°C	Static Load, kN at 20°C
6300 BHTS FB 400°	10	35	11	90	2,38	4,14
6301 BHTS FB 400°	12	37	12	85	2,86	4,98
6302 BHTS FB 400°	15	42	13	80	3,72	6,48
6303 BHTS FB 400°	17	47	14	75	4,52	7,86
6304 BHTS FB 400°	20	52	15	70	5,86	10,2
6305 BHTS FB 400°	25	62	17	65	7,98	13,68
6306 BHTS FB 400°	30	72	19	60	11,24	19,56
6307 BHTS FB 400°	35	80	21	55	13,10	22,80
6308 BHTS FB 400°	40	90	23	50	17,20	30,00
6309 BHTS FB 400°	45	100	25	45	22,00	38,40
6310 BHTS FB 400°	50	110	27	40	26,20	45,60
6311 BHTS FB 400°	55	120	29	40	32,70	57,00
6312 BHTS FB 400°	60	130	31	40	35,90	62,40
6313 BHTS FB 400°	65	140	33	40	41,38	72,00
6314 BHTS FB 400°	70	150	35	40	46,90	81,60
6315 BHTS FB 400°	75	160	37	40	52,76	91,80

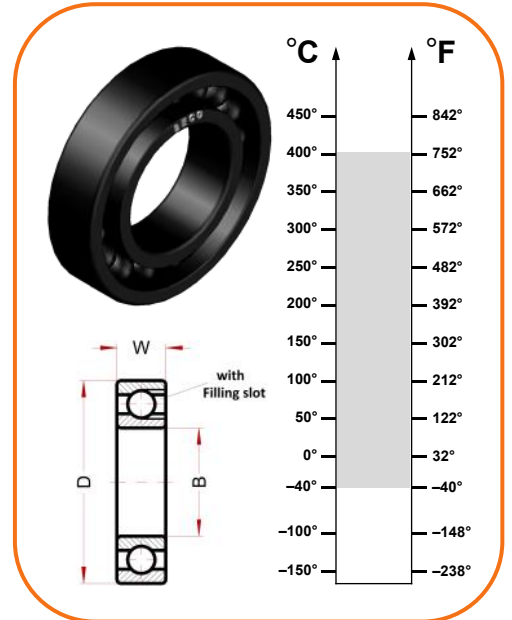

### Technical characteristics:

- Bearing material: steel AISI 52100 (Chrome) stabilized to the application
- Treatment of manganese phosphate coating on all steel parts of the bearing
- Radial Clearance 4x C5
- Bearing running open
- Supplied without lubrication
- Lubrication according customer specification
- Bearing requires Relubrication

### Fields of application:

- Paint Ovens
- Steel industry
- Furnaces for Ceramic Industry
- Trolley Industry, Trolleys for Brick Kilns Industry



12100 Cuneo - Italy

phone: 0039 0171 66883

mail: office@becoitalia.biz

www.becoitalia.biz